

# I9422 Zero Client Quick Start Guide

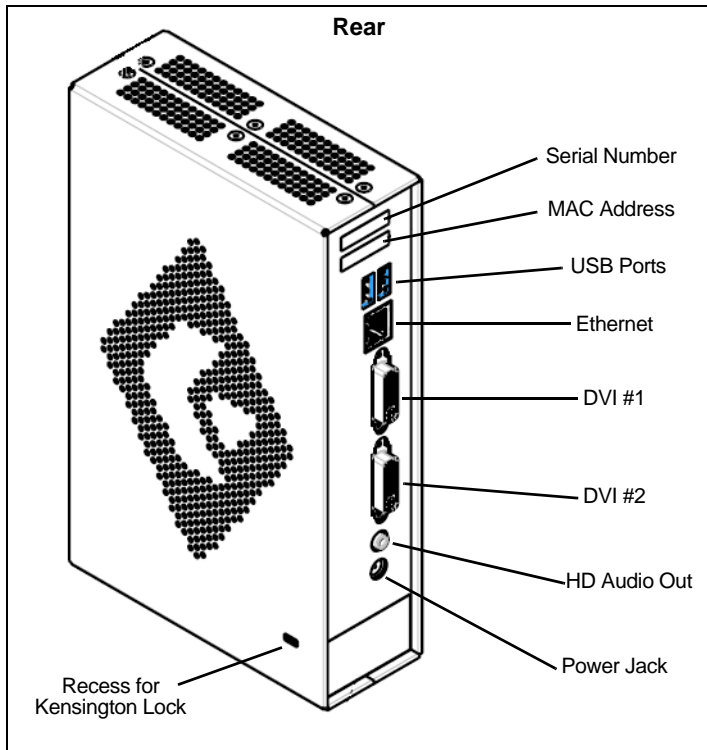

CLEARCUBE

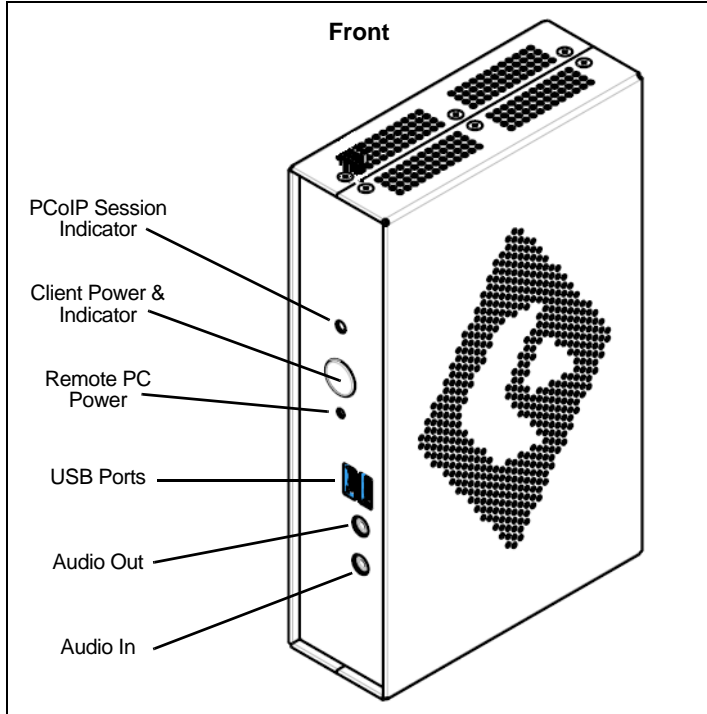

## I9422 Zero Client Overview

ClearCube® I9422 Zero Clients connect to supported ClearCube PC blades containing V5x20 Dual Host cards to provide the following features:

- Support for up to two independently-configurable monitors
- PC-over-IP™ (PCoIP™) processors, delivering PC video and audio over your IP network
- Four USB ports
- Standard audio in and out (front) and HD audio out (rear)

In typical ClearCube environments, ClearCube PC blades are centrally located in data centers. A blade user has an I9422 Zero Client on their desk, connected over an IP network to a blade containing a V5x20 Dual Host card. The I9422 provides the interface to the blade. That is, the user can connect monitors, pointing devices, and other peripherals to the I9422 to receive peripheral data sent from a blade and to send USB data to the blade.

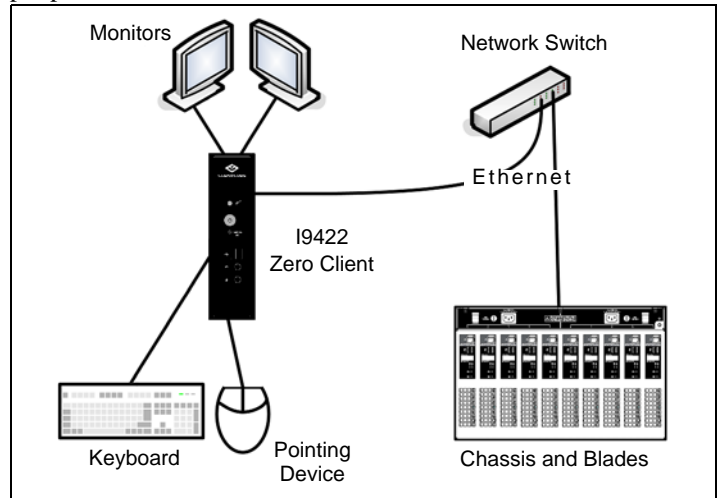

I9422 Zero Client with peripherals & network connection to blades

## Ensuring Client & Host Firmware Compatibility

ClearCube PCoIP clients and host cards must use identical firmware versions. If you are upgrading portions of existing ClearCube deployments, ensure that all PCoIP devices use the same firmware version. Additionally, devices must use firmware version 3.0 or higher in a VMware® View environment. See *PCoIP User's Guide* on the ClearCube Support site for instructions about identifying and updating PCoIP device firmware.

## Setting up the I9422 Zero Client

Perform the following steps to connect peripherals and a network cable to the I9422. **ENSURE YOU FOLLOW THE MOUNTING & COOLING REQUIREMENTS DETAILED BELOW. FAILURE TO DO SO CAN DAMAGE THE CLIENT.**

—Continued on Reverse—



## CLEARCUBE

1. Connect a USB keyboard and a pointing device to the USB ports on the front or the rear of the I9422.
2. Connect a CAT5 or CAT6 Ethernet cable to the RJ-45 Ethernet jack on the rear of the I9422.
3. Connect a monitor cable to each DVI-I port on the rear of the I9422. If you are using VGA monitors, attach DVI adapters to your monitor cables.
4. Connect the AC power adapter, included with the I9422, to the power jack on the rear panel of the I9422.
5. Connect the AC power adapter to the AC power cable, and then plug the cable into a power outlet.
6. To power on the I9422, briefly press the power button on the front of the I9422. The button turns green.
7. To power off the I9422, press and hold the power button for three seconds. The button turns orange when power is off.

### Mandatory Setup & Cooling Requirements

Place the I9422 on a flat surface, as shown in the figures on the previous page. Ensure the following in all scenarios:

- Ensure at least 4 inches of space around all client edges and at least 2 inches of space above the client.
- Ambient temperature around a client must not exceed 35° C (95° F).
- Do not stack any objects on top of the client.
- Do not block the client's side vents by leaning papers, folders, computer speakers, or any other objects against the sides of the client.
- Adjacent furniture (file drawers, desk supports, chairs) do not block or enclose any sides of the client.
- Ensure that the client is standing vertically.
- Do not place the client in enclosed environments such as on a shelf or inside a drawer.
- Cables connected to the client are supported.

### I9422 Zero Client Buttons and Indicators

The I9422 has the following indicators on the front panel:

- **Power Button**
  - Green: I9422 is powered on.
  - Orange: I9422 is powered off.
- **PCoIP Session Indicator**—Shows when a connection, or session, is established between the I9422 and a blade. The link indicator displays one of the following:
  - Green—A session is established between the client and a blade.
  - Off—There is no session between the client and a blade.
- **Remote PC Power**—When an I9422 is connected to a remote PC host, you can press the **Remote PC** button on the front of the I9422 to put the remote PC in a soft off (S5, hot) power state (use a writing pen or a similar object to press the remote power button). Press the button again to wake the remote PC. Video resumes at the OS login screen. You can change the action performed when users press the Remote PC

power button. See the *PCoIP User's Guide* for more information.

### Configuration Steps and Additional Information

See *PCoIP System User's Guide* at [support.clearcube.com](http://support.clearcube.com) for information about configuring the I9422 Zero Client and for instructions about provisioning PCoIP processors on the I9422 Zero Client.

Email: [support@clearcube.com](mailto:support@clearcube.com)

Web site: [support.clearcube.com](http://support.clearcube.com)

Toll-free: (866) 652-3400

Phone: (512) 652-3400

### FCC Compliance & Patent Information

This device complies with part 15 of the FCC Rules. Operation is subject to the following two conditions: (1) This device may not cause harmful interference, and (2) this device must accept any interference received, including interference that may cause undesired operation.

The ClearCube C3 architecture and all its components are protected by granted and pending U.S. and international patents including: US05926172, US05966056, US05994952, US06012101, US06020839, US06037884, US06038616, US06119146, US06148182, US06167241, and US06886055.

#### WEEE Disposal Guidelines

In the European Union, this electronic product is under European Directive (2002/96/EC) WEEE. When this product reaches the end of its useful life or is no longer used, do not discard it with conventional waste. Recycle this product at an approved, designated recycling or treatment facility. Check with local authorities for proper disposal instructions. For assistance, contact ClearCube at [recycle@clearcube.com](mailto:recycle@clearcube.com)

